



18 Verdon Court Petrie QLD

3 1 2

OPEN HOME CANCELLED

Adam Charlton is proud to present to the market 18 Verdon Court, Petrie.

This charming 3 bedroom, 1 bathroom property with a 2 car garage is located in a peaceful Cul de sac, offering a tranquil and private living environment.

Upon entering, you will be greeted by the open plan kitchen, dining, and living area - perfect for entertaining guests or simply relaxing with your loved ones. The bedrooms and lounge room feature vinyl floorboards for easy maintenance and a modern touch.

With aircon and fans throughout the entire house, you can stay cool and comfortable all year round. Step outside to

Price : Offers Over \$649,000
Land Size : 641 sqm
View : <https://www.movementrealty.com.au/sale/ql/city-north/petrie/residential/house/7981773>



Adam Charlton
07 5495 8001

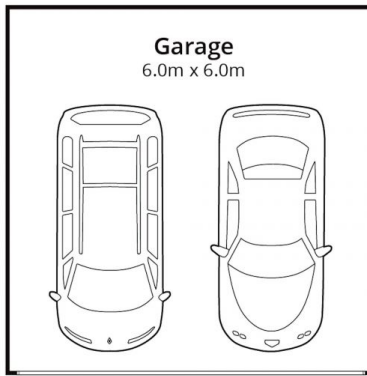

(Not In Position)

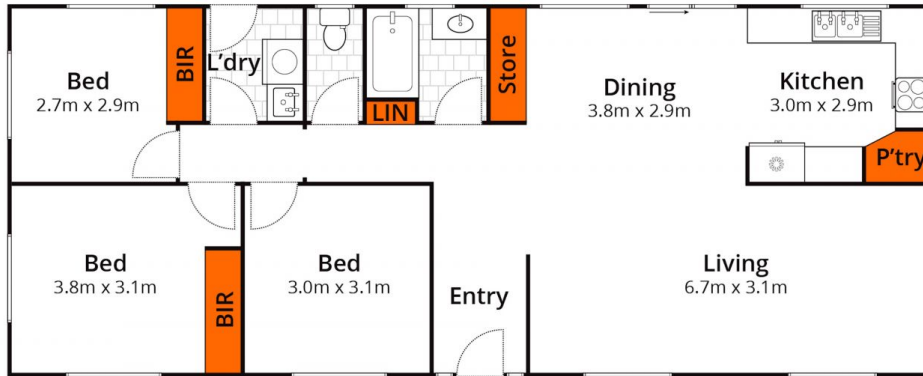

Approx House Area 94m²

Whilst bwrn.com.au has made every attempt to ensure the accuracy of the floor plan contained here, measurements are approximate and no responsibility is taken for any error, omission, or mis-statement. This plan is for illustrative purposes only.

18 Verdon Court, Petrie

MOVEMENT
REALTY